

TF1011X Single bulb-failure bypass relay

Data Sheet

This device incorporates a single relay.
It is typically used to switch a single lamp, usually the fog lamp.

On most vehicles the switching function is controlled by the application of a current to the coil input wire but increasing numbers of vehicles have earth-switched fog lamps and in these vehicles this relay can also be earth-switched. (See relevant diagram below)



Diagram 1: Normal installation

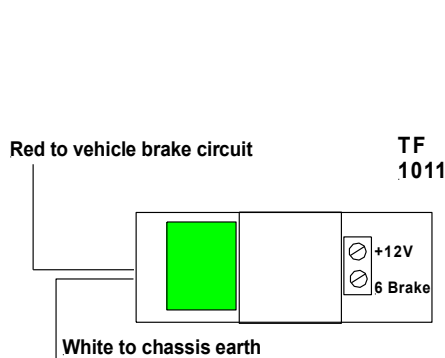
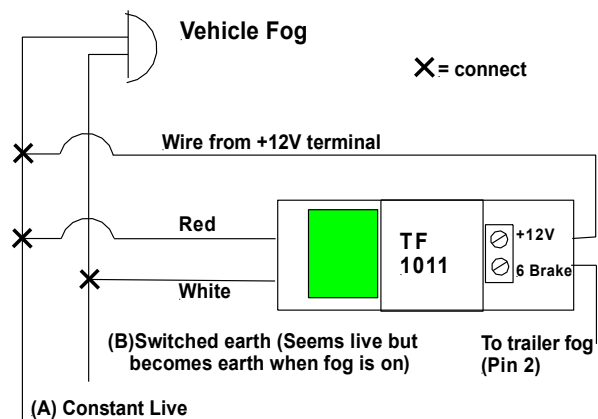

Diagram 2: Installation for a negative-switched fog light



Operation:
When vehicle fog light is switched on, line (B) becomes an earth and switches the trailer fog-lamp on.

Both the +12V terminal AND the red wire are connected to the constant live wire

Fitting the TF1011 (Standard application)

Refer to the general instructions in Appendix 3 at the back of this manual.

Connect the appropriate wire of the 7-core cable to the terminal of the relay marked "6 Brake".

(You will have selected which circuit you wish the relay to control.)

Connect the thin red signal wire to the vehicle's circuit that you have selected.

Connect white to a good chassis earth.

Bring a reliable power line (1.0mm²) from the vehicle battery to the +12V terminal. Fuse this cable close to the battery using a 5amp fuse.

Do not connect to the battery or insert the fuses until the rest of the installation is complete.

Connect the remaining 7-core wires to the loom as follows but use the TF1011 relay on the single circuit you have selected.

Connect the brown wire of the 7-core to the vehicle RH Tail light circuit*.

Connect the black wire of the 7-core to the vehicle LH Tail light circuit*.

Connect the red wire of the 7-core to the vehicle brake light circuit*.

Connect the blue wire of the 7-core to the vehicle fog lamp circuit*.

Connect the flasher circuits following the instructions with the flasher relay you are fitting*.

* It is important that you check whether or not to fit bypass relays to these circuits. These instructions assume that you have made this check correctly.

When the installation is complete, make the battery connection, insert the power fuse and test the operation.

Dimensions	L: 85mm W: 25mm D: 18mm
Weight	23grams
Voltage	12V
Coil current	38mA
Max load	10 amps

Quality – Service – Innovation

Unit 1, Chadwick Block, Bracewell Ave Poulton-le-Fylde, Lancashire, FY6 8JF, Phone: 01253 881008 (Fax: 01253 886434)

(www.rydertowing.co.uk mail@rydertowing.co.uk)